

MK7 Motorized Ball Valve

Common Specification



Item	Description
Rated Consumption	<ul style="list-style-type: none"> • AC100, 110, 115V 50/60Hz • AC200, 220, 230V 50/60Hz
Power Consumption	80VA
Media	Oil, Air, Water
Fluid temp.	-5 ~ 120°C
Ambient Temp.	0 ~ 50°C
Max. Pressure Diff.	10 kgf/cm ²
Max. Pressure	20 kgf/cm ²
Dust/Waterproof	IP65
Time for 90°	~7 sec (60Hz) ; ~7.5 sec (50Hz)
Installation	Vertical ± 15°

Features

- MK 7 actuator is fit for assembling with 2 way / 3 way ball valves.
- Material of ball valve can be SCS 304 or SCS 316.
- Acting time is 7 seconds from close position to open position.
- Pressure range from 0 to 10 kg*f/cm.
- Potentiometer unit 1K Ohm.(Optional accessories)

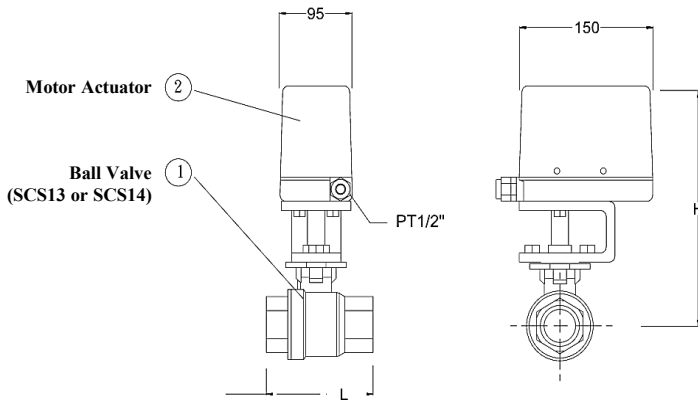

Dimensions (mm) - 2Way Ball Valve

Model	Size	L	H	Weight (kg)
MK7-SSP15	15A	69	223	3.5
MK7-SSP20	20A	80	228	3.6
MK7-SSP25	25A	90	233	3.8
MK7-SSP32	32A	106	240	4.2
MK7-SSP40	40A	120	250	5.5
MK7-SSP50	50A	140	260	8.5

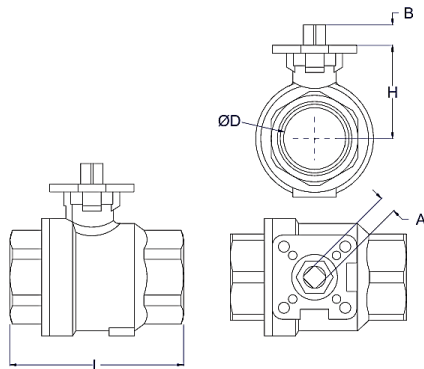

2Way Full Port Ball Valve (mm)

Size	ØD	L	H	A	B	ISO 5211
1/2"	15	69	35	9	10	F03-F04
3/4"	20	80	39	9	10	F03-F04
1"	25.4	90	45	11	14	F04-F05
1-1/4"	32	106	56	11	14	F04-F05
1-1/2"	38	120	63	14	19.5	F05-F07
2"	50	140	75	14	19.5	F05-F07